

Floating and Pitch Compensating Tap Holders

Floating tap holders provide lateral adjustment for operations having open tolerances on hole locations such as stampings or die castings. Pitch compensation tap holders are used to vertically compensate for variations between drill press spindle feed rate and tap lead. Also, they are used on multiple spindle heads, ratio 1:1, requiring taps of different leads.

Style 1 tap holders have vertical adjustment and lateral float. Vertical adjustment of tap is simple, no wrenches or special tools required; just lift knurled top collar and reposition mating serrations of holder and spindle. Float is pivotal and perpendicularity or accuracy of finished holes will be proportional to part hole location tolerances. The tap shank square is used for drive, while a loose running fit at the shank round area provides the float. Tap retention in the chuck is accomplished by an insert engaging a notch in the tap shank diameter.

Style 2 pitch compensation tap holders have vertical float in addition to the same features of style 1. Its design requires the drill press feed rate to be less than tap lead. Vertical float eliminates special drill press feed gears, lead screws or special multiple spindle head ratios.

Ordering Information:

1. Order by part number; one assembly required for each tap size.
2. Specify tap size.
3. Tool holders on existing equipment are identified by the spindle size, outside diameter and length.

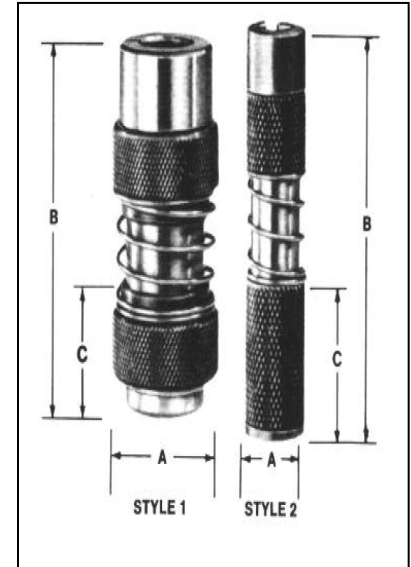

SPECIFICATIONS									
Series	Style	Assembly Part No	Tap Capacity	Dimensions			Vertical Adjustment	Serrated Spindle	
				A	B	C		Diameter	Pitch
4000	1	4000.XXX-00	#0 to 1/4	0.75	1.94	0.81	0.25	0.375	0.040
4100	1	4100.XXX-00	#0 to 5/16	0.91	1.94	0.81	0.25	0.4375	0.040
4600	1	4600.XXX-00	#10 to 13/16 1/16 to 3/8 NPT	1.25	2.78	1.13	0.44	0.625	0.062
4600L	1	4600.LXX-00	9/16 to 1 1/8 1/16 to 3/4 NPT	1.63	2.88	0.50	0.44	0.625	0.062
6000	2	6000.XXX-00	#0 to 3/16	0.91	2.75	0.66	0.25	0.4375	0.040
6600	2	6600.XXX-00	#0 to 1/4	0.60	2.63	0.66	0.25	0.375	0.040

Part numbers with X to be completed by Creattech - specify tap size. C = depth that tool enters holder
* Dimension to bottom of shank square 4600L only

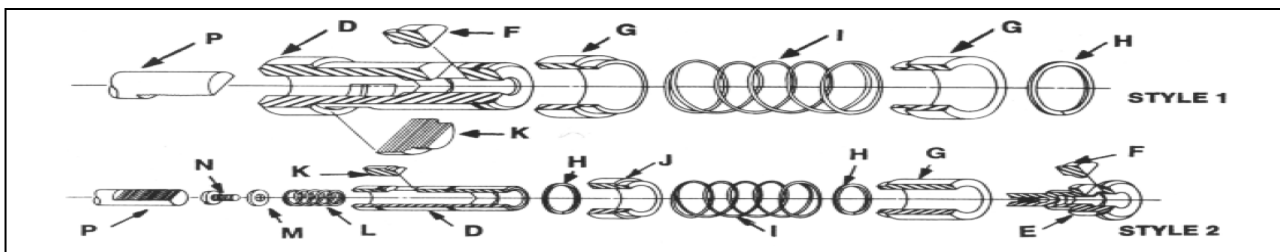

REPLACEMENT PARTS													
Series	Style	Body D	Tap Insert E	Tap Lock F	Bottom Collar G	Retaining Ring H	Collar Spring I	Top Collar J	Spindle Lock K	Compensating Spring L	Washer M	Screw N	Serrated Spindle Dia P
4000	1	4001XXX00	NR	4003XXX00	400400000	400500000	400600000	NR	400200000	NR	NR	NR	0.375
4100	1	4101XXX00	NR	4103XXX00	410400000	410520000	410600000	NR	410200000	NR	NR	NR	0.4375
4600	1	4601XXX00	NR	4603XXX00	460400000	460500000	460600000	NR	460200000	NR	NR	NR	0.625
4600L	1	4601LXXX0	NR	4603LXXX0	4604L0000	4605L0000	4606L0000	NR	4602L0000	NR	NR	NR	0.625
6000	2	600100000	6002XXX00	4103XXX00	603000000	410520000	410600000	410400000	410200000	600500000	600600000	600400000	0.4375
6600	2	660100000	6602XXX00	6606XXX00	660400000	NR	660900000	660300000	660500000	660700000	NR	660800000	0.375

Part numbers with X to be completed by Creattech - supply tap size and original equipment serial numbers. NR = Not required